

# Magnetflex® Double Hinge Max-Line 1”

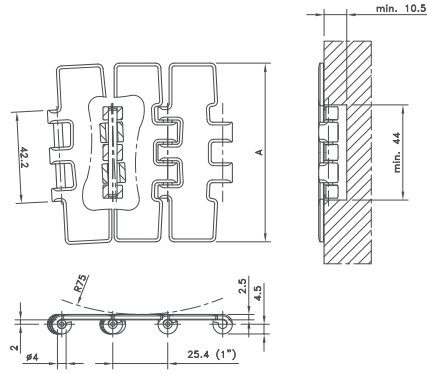

Chain Type	Code Number	Plate Width A		Weight kg/m	Surface Flatness (max.) mm	Polished Hinge Eyes	Working Load (max.) N
		mm	inch				
<b>661-Series</b>							
661 M 31 SM	767.09.90	82,5	3,25	1,96	0,10	yes	5100
661 M 84 SM	767.09.91	83,8	3,30	1,97			

Standard length: 3.048 m – 10 feet (120 links).

# Magnetflex® Single hinge Quick Linq

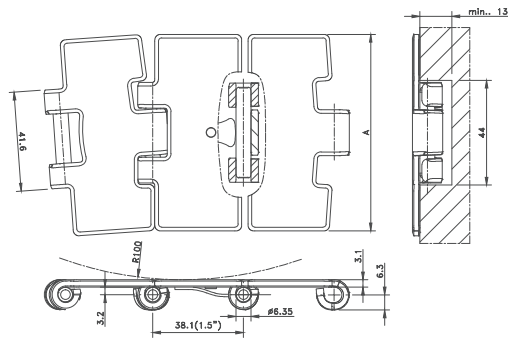
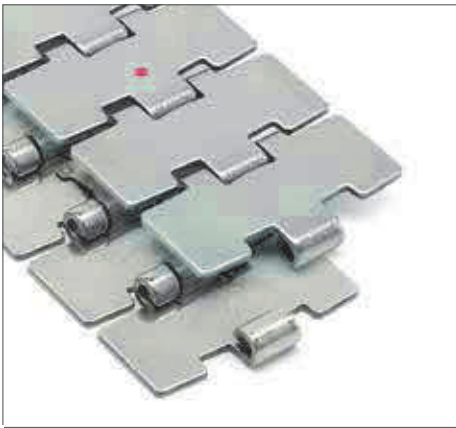

Chain Type	Code Number	Plate Width A		Weight kg/m	Surface Flatness (max.) mm	Polished Hinge Eyes	Working Load (max.) N
		mm	inch				
<b>60 Series Quick Linq</b>							
60S31XM Quick Linq	10384449	82.5	3.25	2.61	0.08	yes	6000
60S84XM Quick Linq	10384450	84	3.30	2.63	0.08	yes	
<b>60 Series HB Quick Linq</b>							
60S31XM HB Quick Linq	10384451	82,5	3.25	2,61	0,08	yes	6000
60S31XM HB Quick Linq	10384452	84	3,30	2,63	0,08	yes	
<b>66 Series XHB Quick Linq</b>							
66S31XM XHB Quick Linq	10384453	82.5	3.25	2.61	0.08	yes	6000
66S84XM XHB Quick Linq	10384454	84	3,30	2,63	0,08	yes	

Standard length: 3.048 m - 10 feet (80 links).